

Schröder

FLEXIA QUERCUS

Midi & Maxi

Suspended

Installation instructions

ENG	INSTALLATION INSTRUCTIONS	ITA	ISTRUZIONI DI INSTALLAZIONE	NLD	INSTALLATIE INSTRUCTIES	DAN	INSTALLATIONSVEJLEDNING	HUN	TELEPÍTÉSI ÚTMUTATÓ
DEU	INSTALLATIONSANLEITUNG	POL	INSTRUKCJE MONTAŻU	RUS	Инструкции по установке	RON	INSTRUCȚIUNI DE INSTALARE	CHI	安装说明
FRA	INSTRUCTIONS DE MONTAGE	SPA	INSTRUCCIONES DE INSTALACIÓN	POR	INSTRUÇÕES DE INSTALAÇÃO	SWE	INSTALLATIONSANVISNING	UKR	Інструкції з монтажу
SRP	UPUTSTVA ZA INSTALACIJU	AR	تعليمات التركيب						

02

 4 m - 10 m / 8 m - 10 m
 220-240V / 50-60Hz
 IP 66 / IK 09

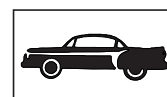
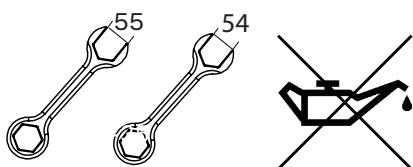

Road side indicator label

← QUERCUS QUERCUS →

Midi Maxi

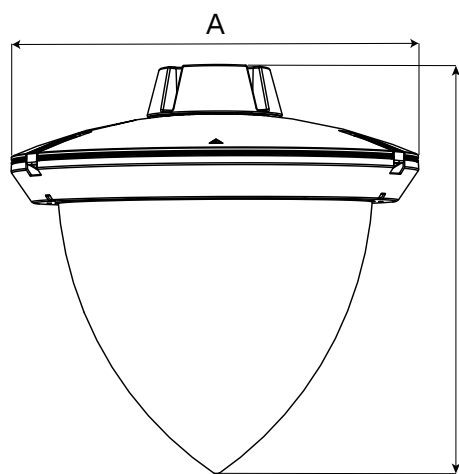

A	Ø504	Ø610
B	490	693
C	336	552
Kg	11,5	16,8
Mass Tolerance (Kg)	+/- 0,8	+/- 0,8

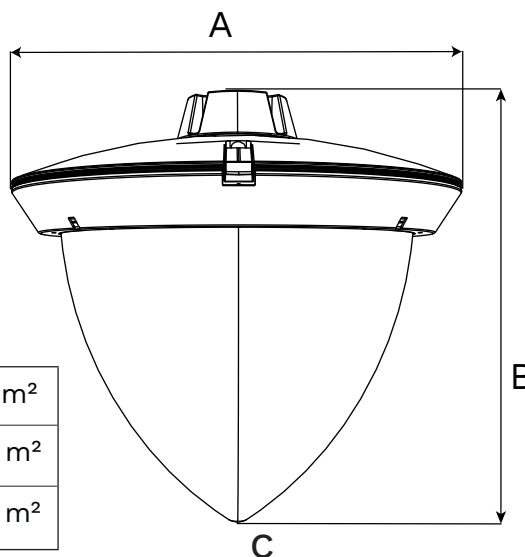

Cd.S	0,098 m ²	0,140 m ²
Cs.S	0,040 m ²	0,004 m ²
Cl.S	0,038 m ²	0,056 m ²

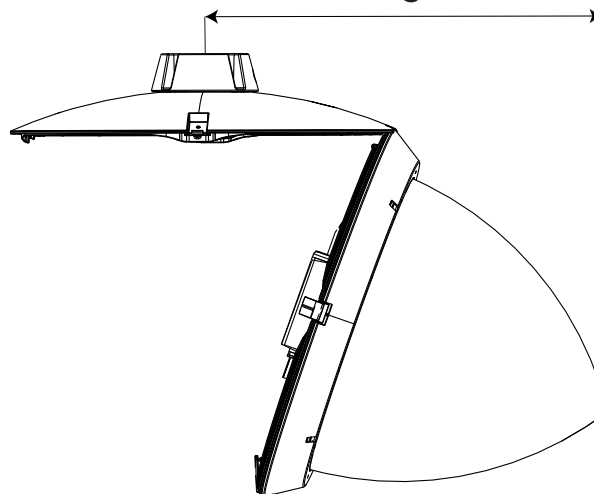
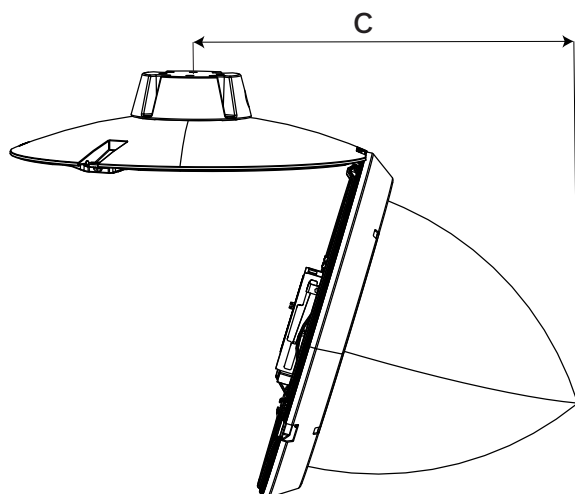

NO FIXATION

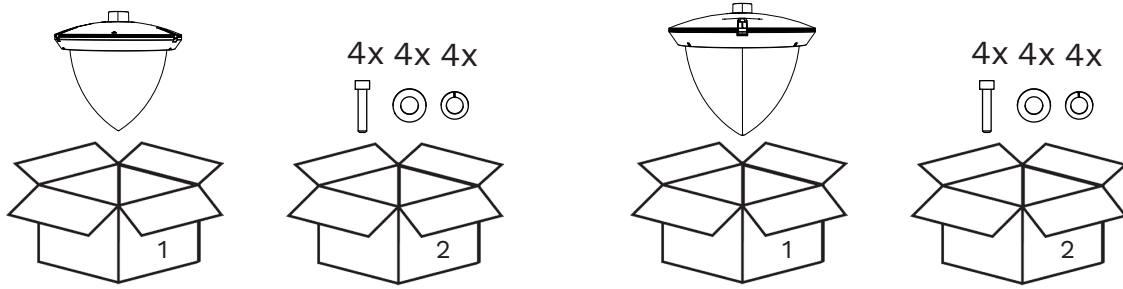

FIXATION MALE ON FEMALE 1"

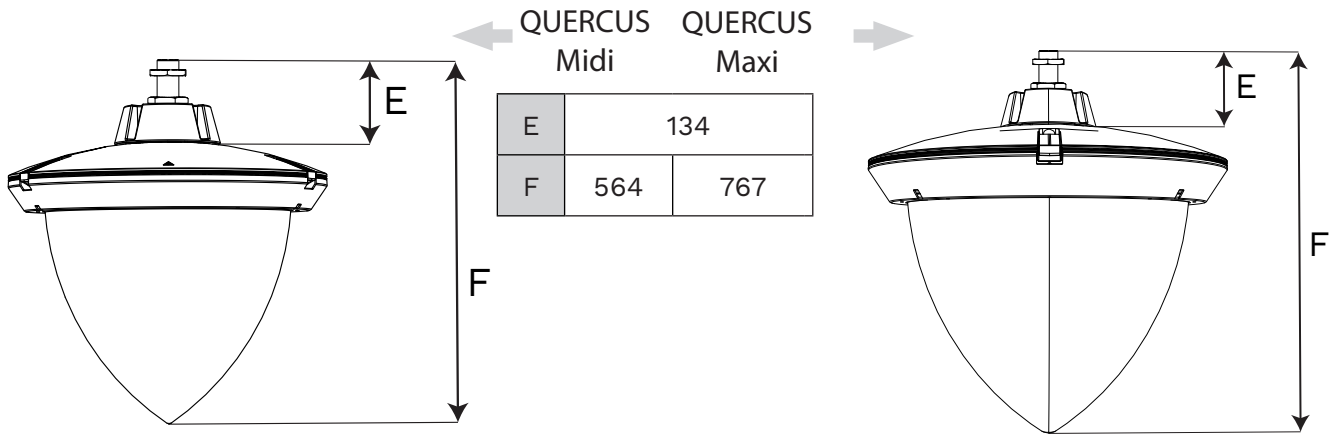

FIXATION FEMALE ON MALE 1"

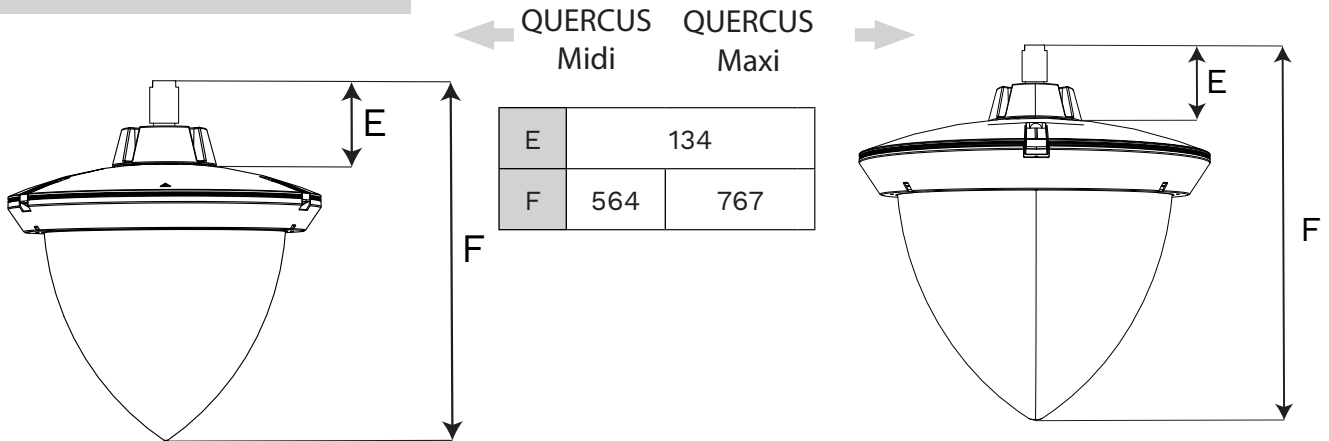

FIXATION MALE ON FEMALE ADJUSTABLE 1" AND 1" ¼

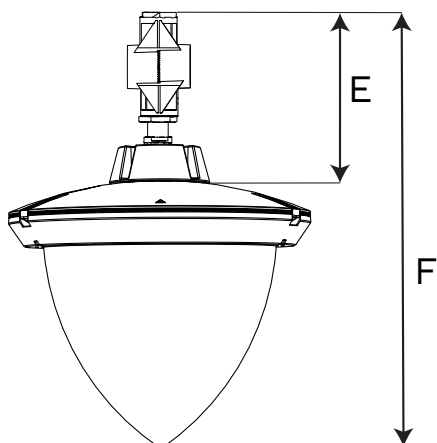

← QUERCUS Midi QUERCUS Maxi →

E	288	
F	718	921

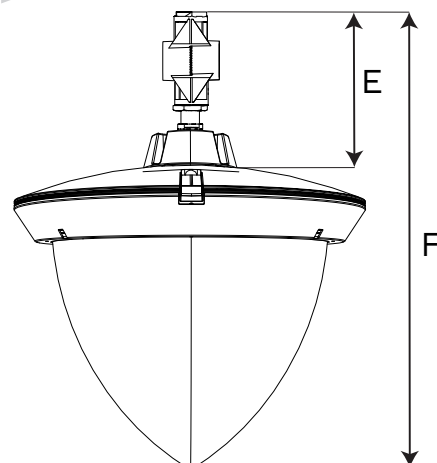

FIXATION FEMALE ON MALE ADJUSTABLE 1"

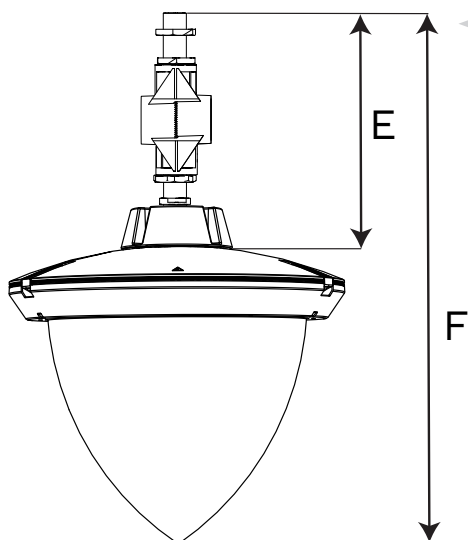

← QUERCUS Midi QUERCUS Maxi →

E	355	
F	785	988

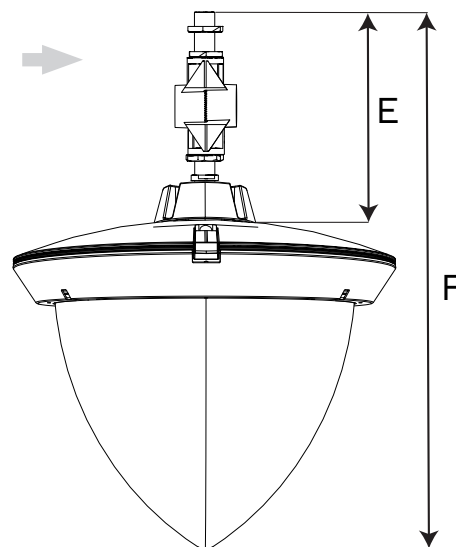



ON TUBE 1"

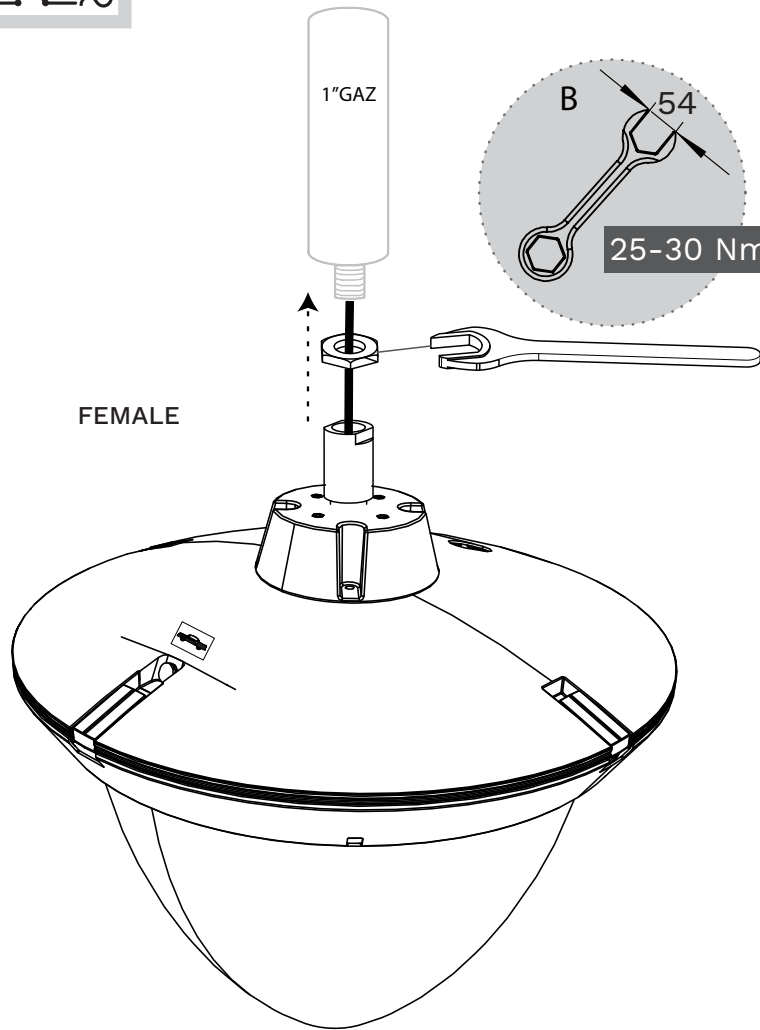

FEMALE

1"GAZ

B 54

25-30 Nm

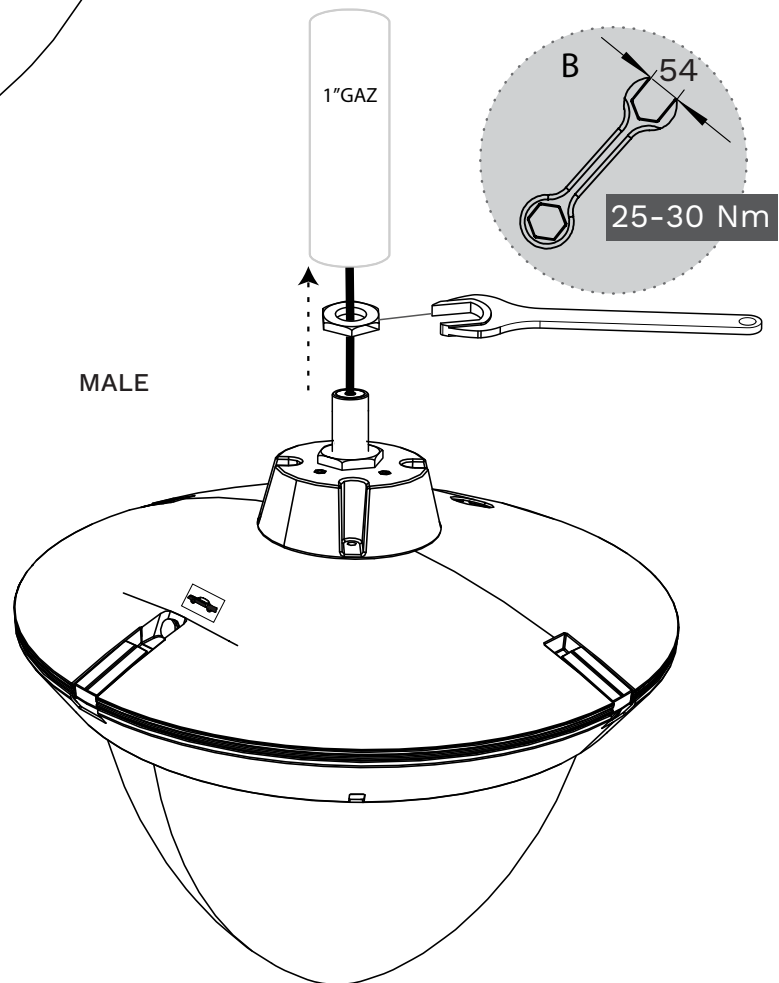

MALE

1"GAZ

B 54

25-30 Nm



ON TUBE 1" ¼

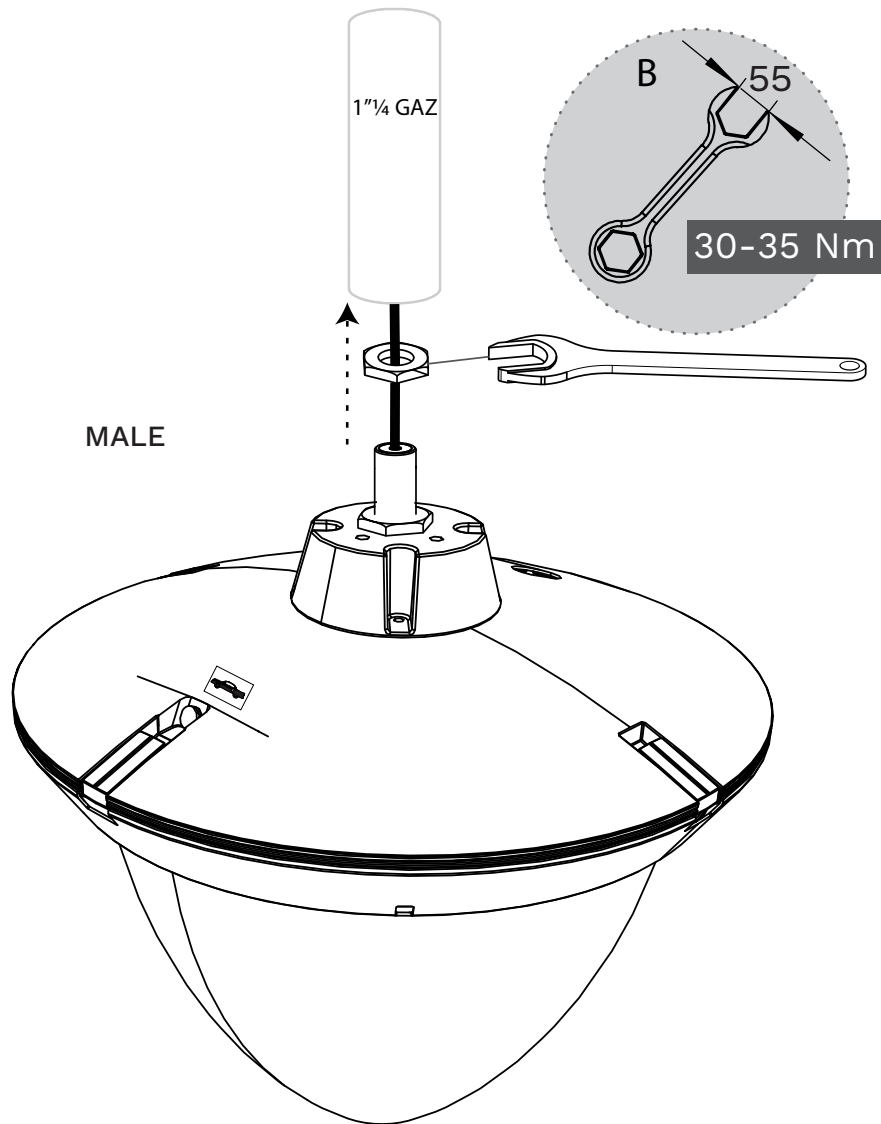

B



ONTUBE1"ADJUSTABLE

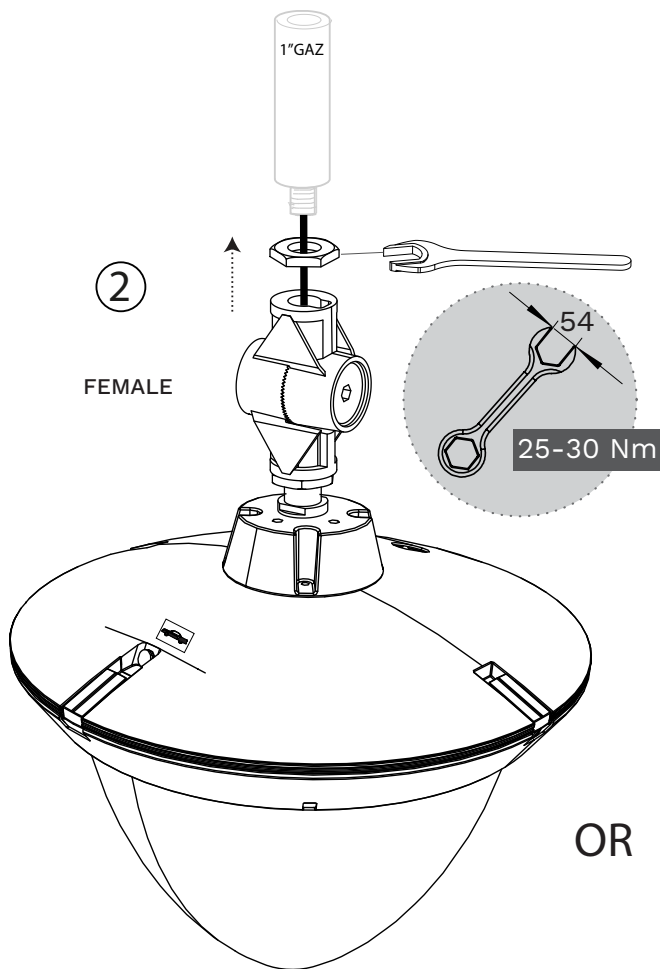
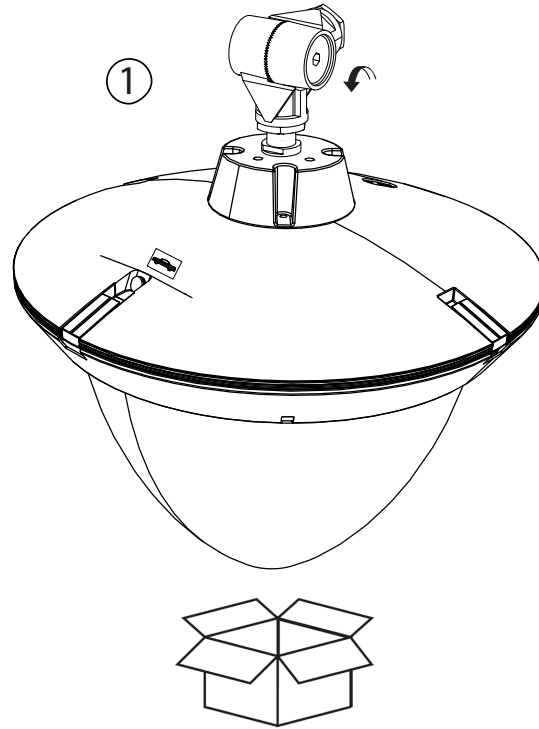

OR

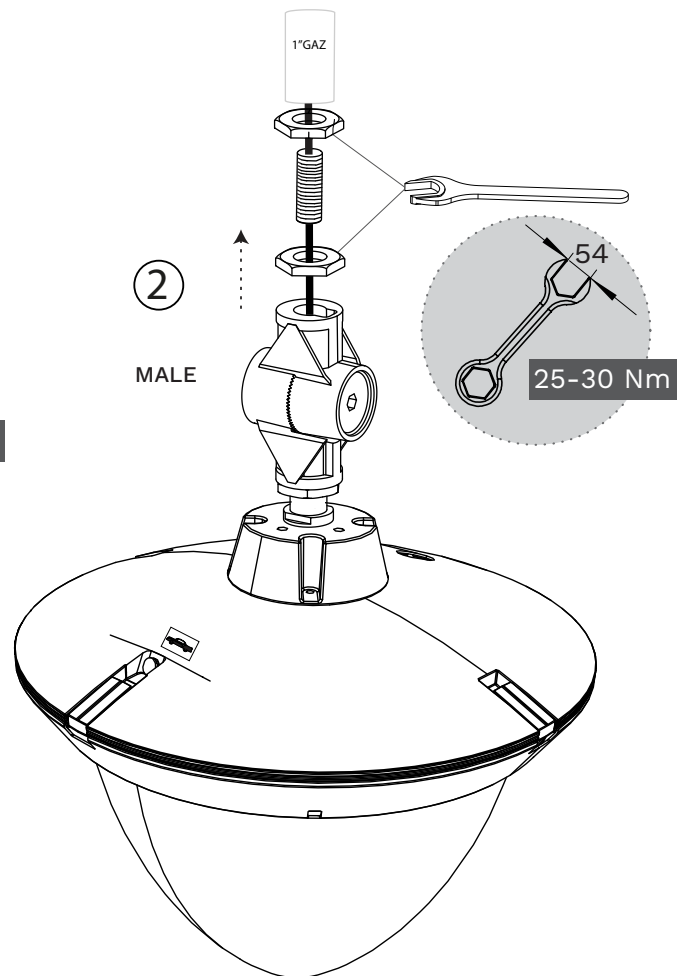

C

MAINTENANCE Midi & Maxi (CR-KIT EU)

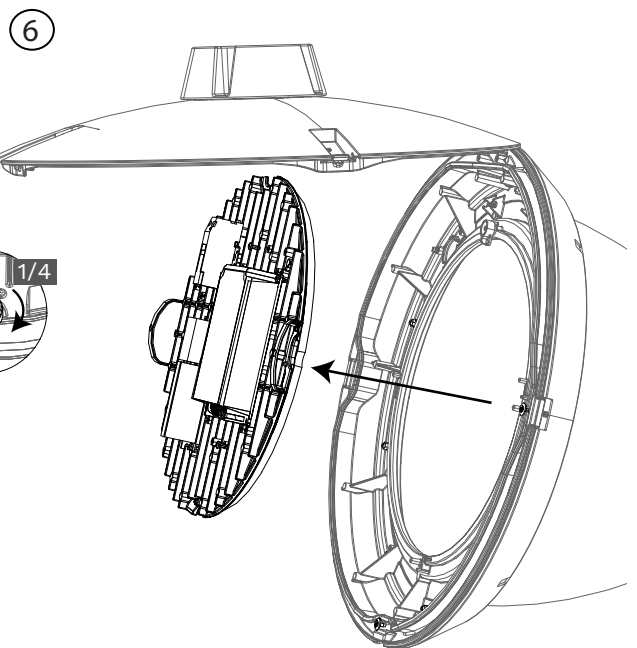
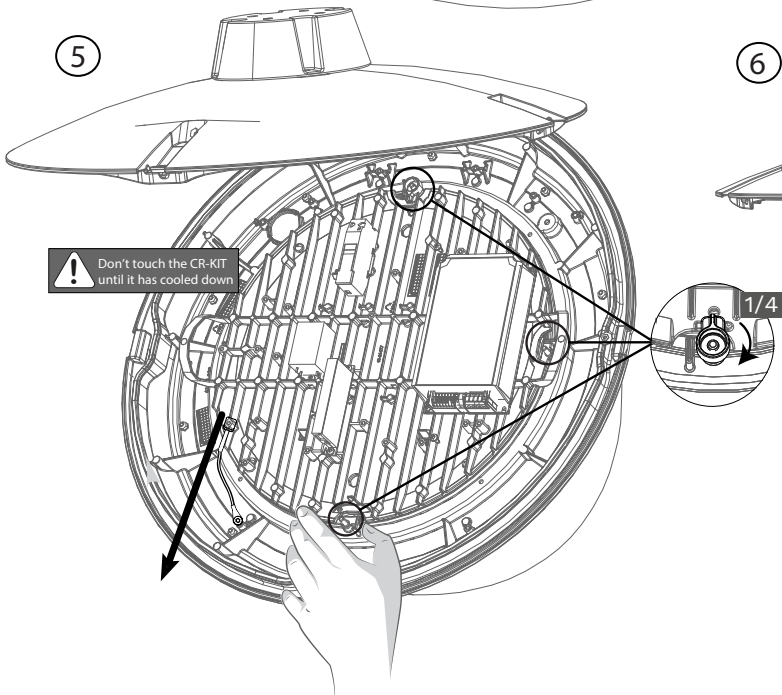
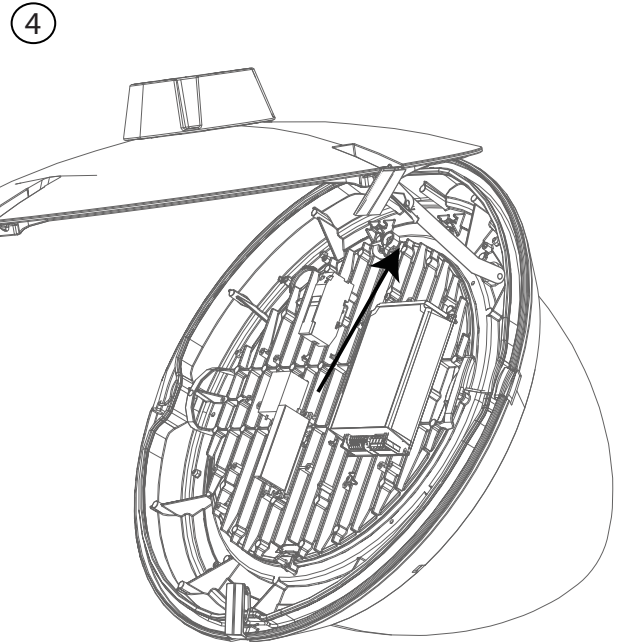
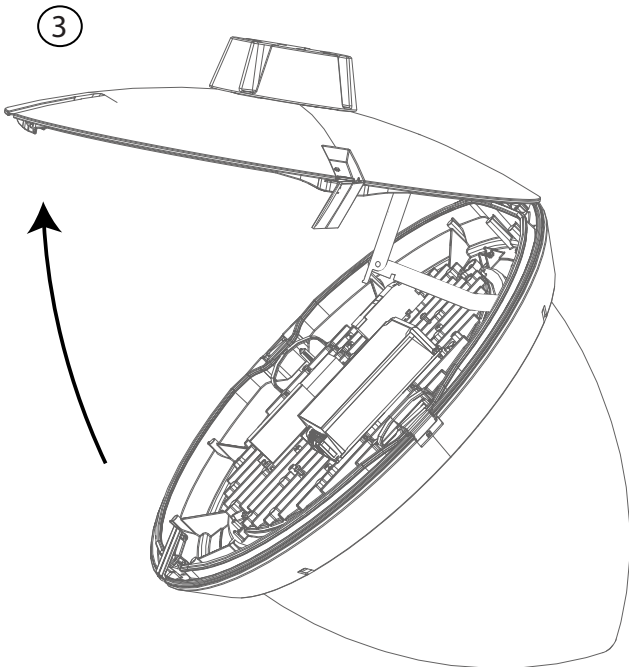
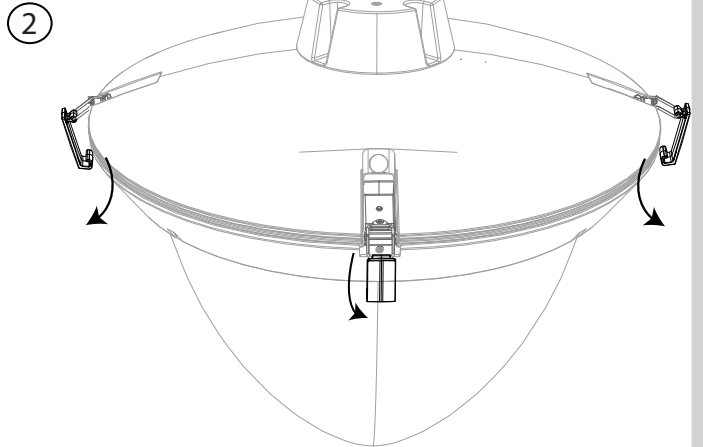
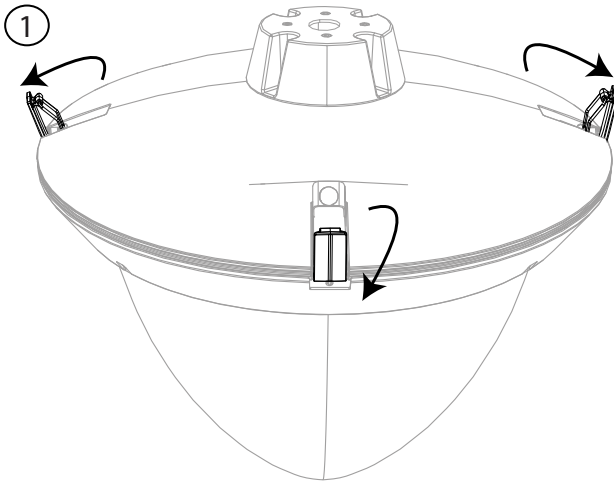

REASSEMBLING

④

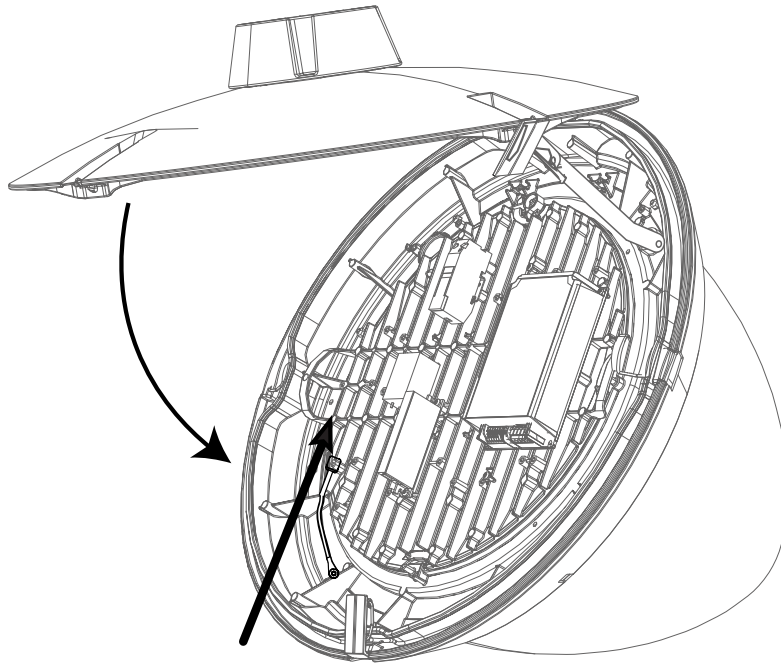

⑤

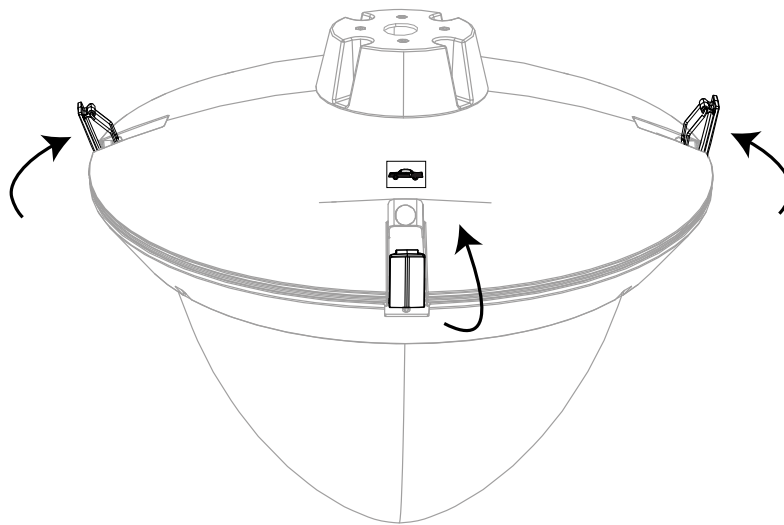

⑥

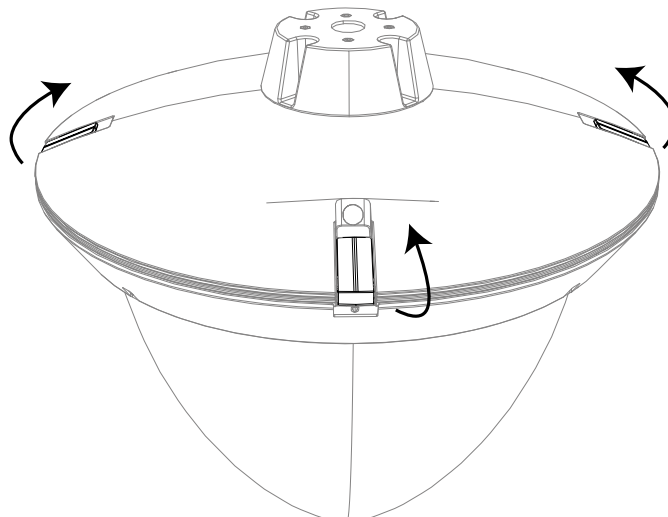

C

MAINTENANCE Midi & Maxi (CR-KIT CSA/UL)



①

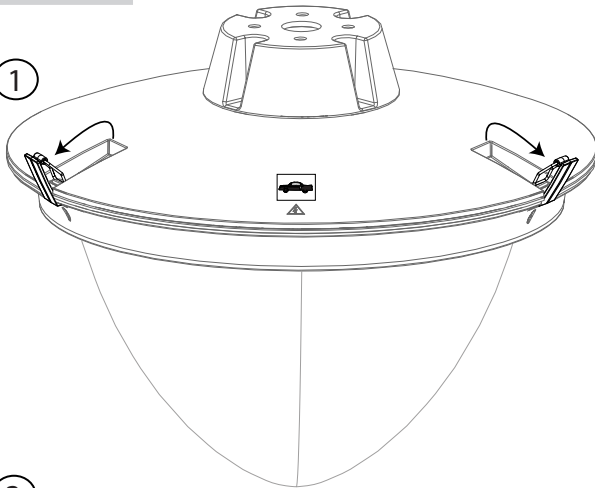

②

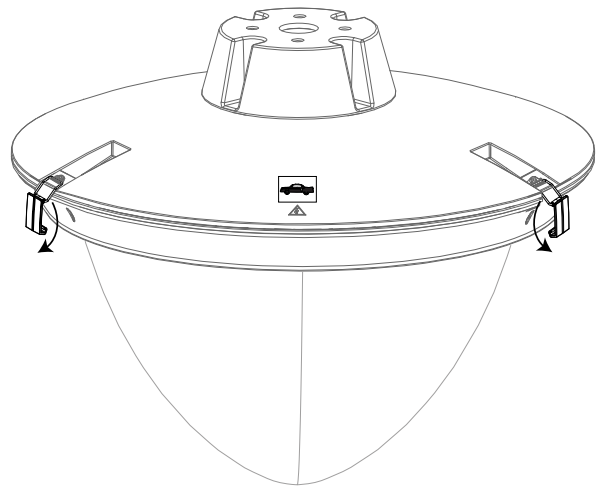

③

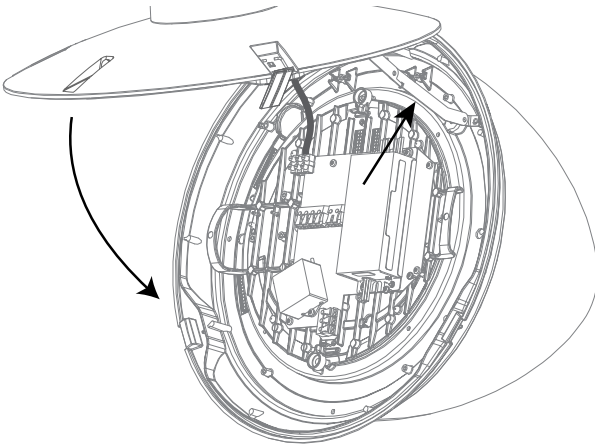

④

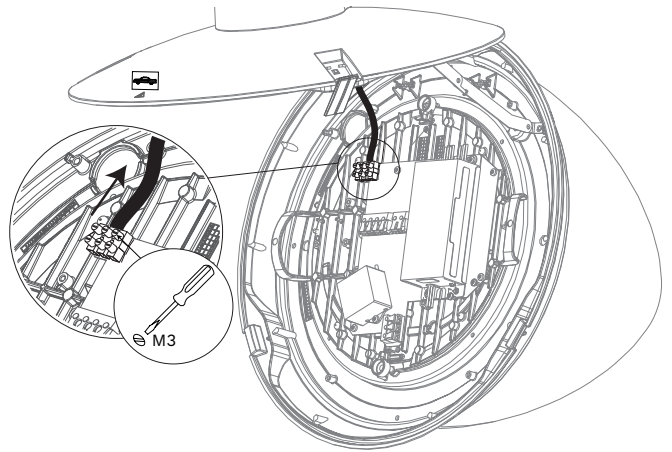

⑤ IF NEMA

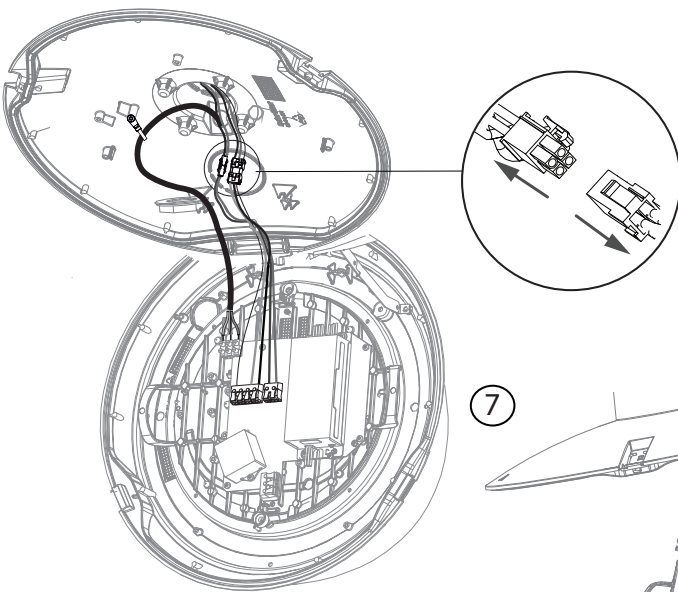

⑥

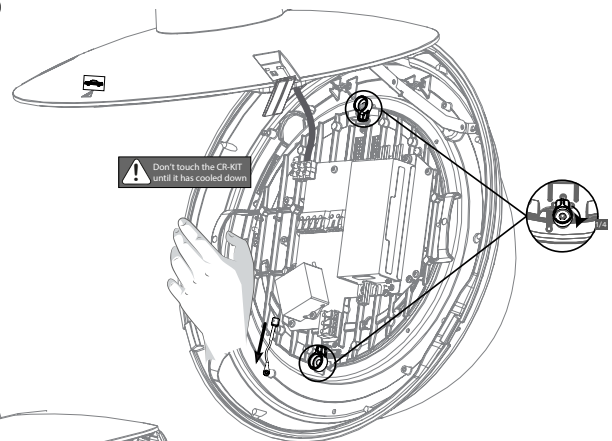

⑦

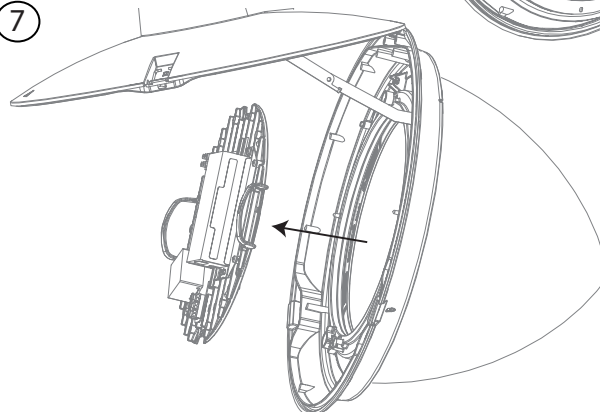

REASSEMBLING

①

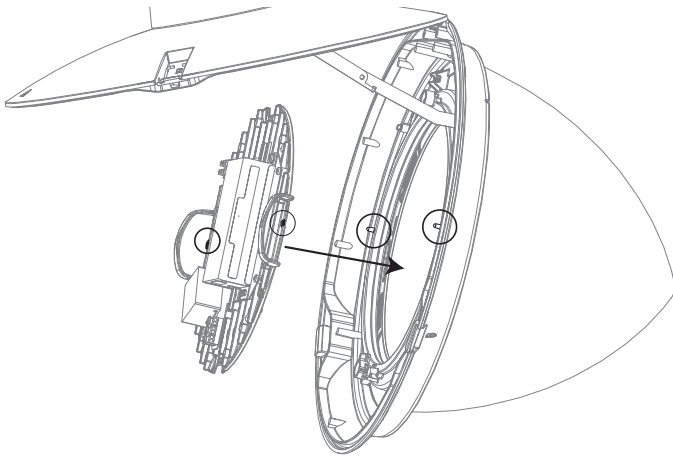

②

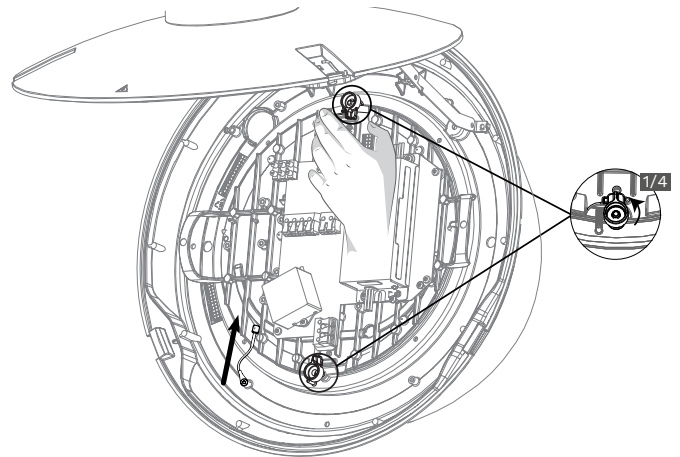

③

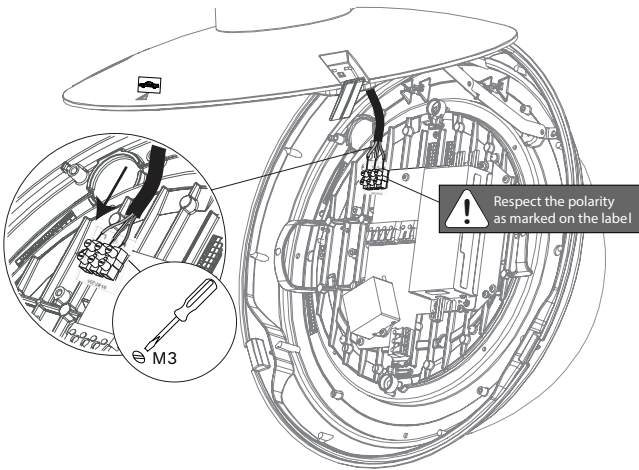

④

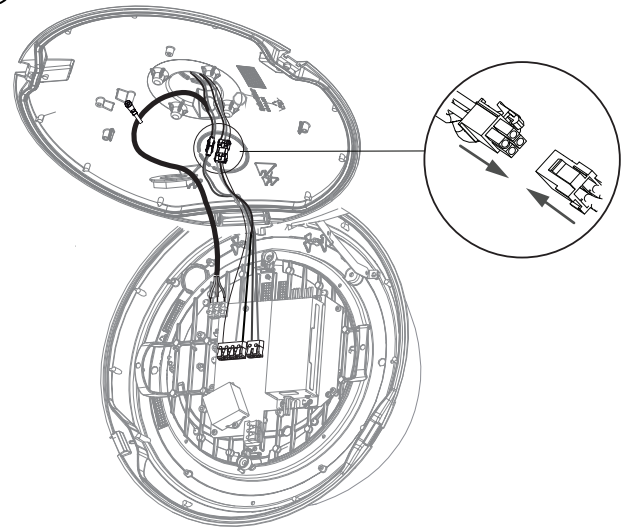

⑤

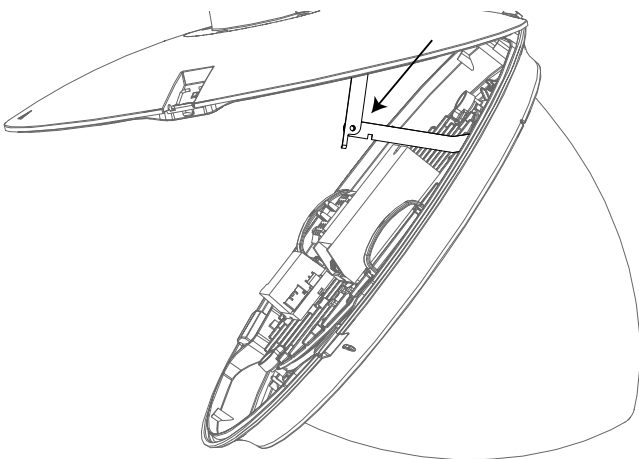

⑥

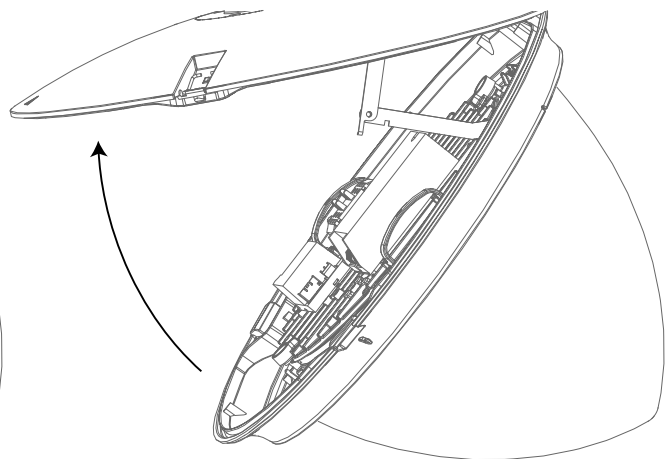

REASSEMBLING

7

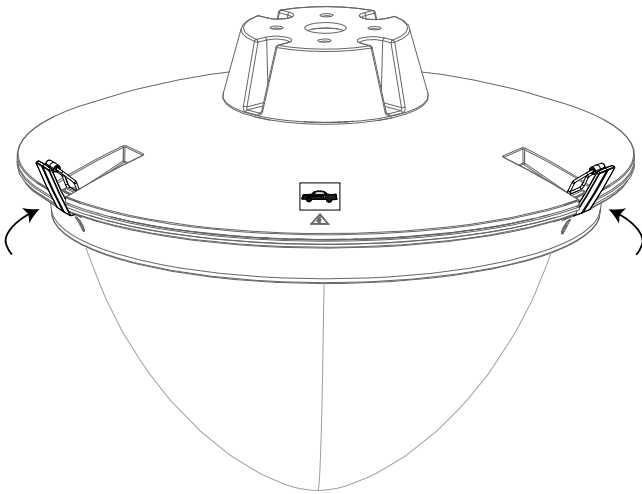

8

