

VITALUM EVO

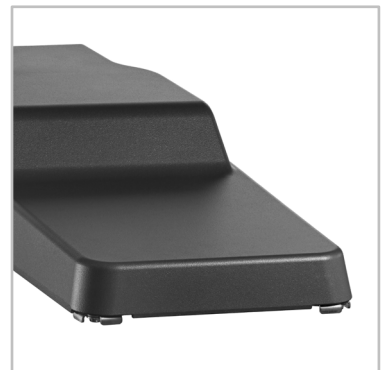

Efficiency meets functionality in a design built for performance

VITALUM EVO is a next-generation luminaire range designed to deliver optimal lighting for various road and urban applications. Available with a selection of light distributions, it ensures precise illumination tailored to the specific needs of any project, from quiet residential streets, bicycle paths, bridges and car parks, to busy urban roads.

This photometric versatility is matched by remarkable ease of use. Compact and lightweight, VITALUM EVO simplifies handling and installation on site. Tool-free access to the electronic compartment allows for quick, safe maintenance, reducing downtime and operational costs.

Designed for modern cities and operators seeking both efficiency and reliability, VITALUM EVO stands out as the smart, economical choice for reliable road lighting.



Concept

VITALUM EVO features an optimised, streamlined design, engineered for the greatest convenience and responsible use of raw materials. Made of aluminium and glass, it guarantees a high recycling rate while providing excellent mechanical and tightness performance, ideal for withstanding urban road conditions.

Thanks to the variety of photometric engines and light distributions, this road luminaire, available in two sizes, provides tailored illumination for various types of project. Taking advantage of the latest LensoFlex® and HiFlex™ photometric platforms, VITALUM EVO offers flexible, energy-efficient lighting solutions that can be tailored to meet the specific needs of any road environment, while maximising savings and providing a quick return on investment.

Its energy-efficient photometric engines are complemented by advanced connectivity features for smarter lighting network management. Available with optional NEMA 7-pin and Zhaga sockets (positioned on the top and bottom of the luminaire), VITALUM EVO enables seamless integration into open and interoperable connected lighting systems.

To ease installation and maintenance, this luminaire is available with a universal fixation part adapted for post-top and side-entry mounting on Ø48-60mm spigots. The inclination angle can be adjusted on-site to perfectly match the infrastructure needs. Compact and lightweight, VITALUM EVO is easy to handle and install on various pole and bracket types. Tool-free access to internal components optimises maintenance activities, reduces downtime and enables long-term upgradability.



Compact, lightweight and easy to install.



Fully compatible with Zhaga and NEMA 7-pin sockets, VITALUM EVO easily integrates into various open connected lighting networks.



VITALUM EVO delivers tailored photometric performance for various types of road and urban application.



Sustainable, low maintenance street lighting solution.

TYPES OF APPLICATION

- URBAN & RESIDENTIAL STREETS
- BRIDGES
- BIKE & PEDESTRIAN PATHS
- RAILWAY STATIONS & METROS
- CAR PARKS
- SQUARES & PEDESTRIAN AREAS
- ROADS & MOTORWAYS

KEY ADVANTAGES

- High efficiency with low operating costs
- HiFlex™ photometric engine designed for optimised energy efficiency
- LensoFlex®4 versatile solutions for high-end photometries maximising comfort and safety
- Connected-ready
- Zhaga-D4i certified
- Based on open and interoperable standards
- Compact, lightweight and easy to install
- 2 sizes for flexibility

VITALUM EVO | VITALUM EVO 1



VITALUM EVO | VITALUM EVO 2





LensoFlex[®]4

LensoFlex[®]4 maximises the heritage of the LensoFlex[®] concept with a very compact yet powerful photometric engine based upon the addition principle of photometric distribution. The number of LEDs in combination with the driving current determines the intensity level of the light distribution. With optimised light distributions and very high efficiency, this fourth generation enables the products to be downsized to meet application requirements with an optimised solution in terms of investment.

LensoFlex[®]4 optics can feature backlight control to prevent intrusive lighting, or a glare limiter for high visual comfort.

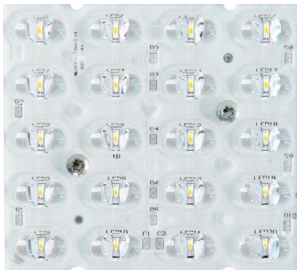

HiFlex[™]

The HiFlex[™] platform is expertly designed to optimise energy efficiency. Its photometric engines feature high-power LEDs that deliver exceptional performance while consuming minimal energy, resulting in unmatched efficacy (lm/W).

Ideal for projects that require a streamlined approach to maximising lighting efficacy and achieving swift ROI, HiFlex[™] is available in two versions: HiFlex[™]1, boasting 24 LEDs and HiFlex[™] 2, equipped with 36 LEDs. Both variants are designed with the priorities of compactness, cost-effectiveness and high performance in mind.



Custom dimming profile

Intelligent luminaire drivers can be programmed with complex dimming profiles. Up to five combinations of time intervals and light levels are possible. This feature does not require any extra wiring.

The period between switching on and switching off is used to activate the preset dimming profile. The customised dimming system generates maximum energy savings while respecting the required lighting levels and uniformity throughout the night.

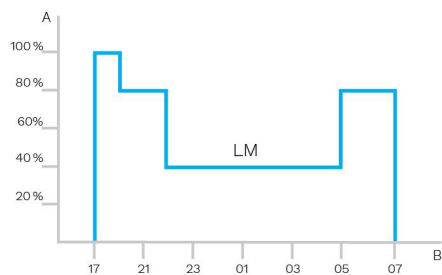

A. Dimming level | B. Time

The Zhaga consortium joined forces with the DiiA and produced a single Zhaga-D4i certification that combines the Zhaga Book 18 version 2 outdoor connectivity specifications with the DiiA's D4i specifications for intra-luminaire DALI.

2 sockets: top and bottom

The Zhaga socket is small and suited to applications where aesthetics is essential. The architecture of Zhaga-D4i also foresees the possibility of putting two sockets on one luminaire, allowing for instance, the combination of a detection sensor and a control node. This also has the added value of standardising certain detection sensor communications with the D4i protocol.

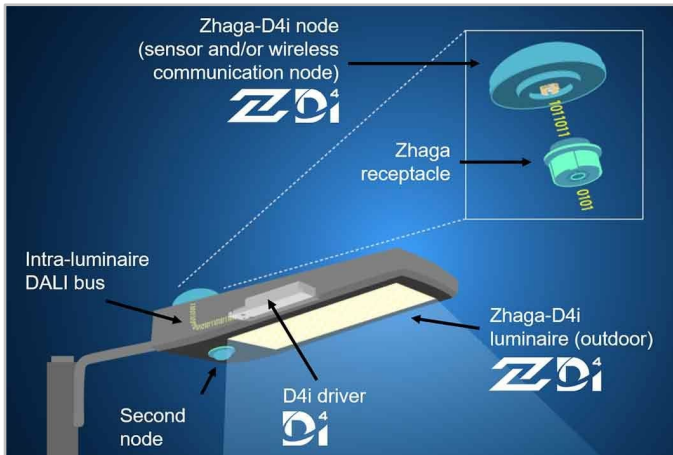

Standardisation for interoperable ecosystems



As a founding member of the Zhaga consortium, Schröder has participated in the creation of, and therefore supports, the Zhaga-D4i certification program and the initiative of this group to standardise an interoperable ecosystem. The D4i specifications take the best of the standard DALI2 protocol and adapt it to an intra-luminaire environment but it has certain limitations. Only luminaire mounted control devices can be combined with a Zhaga-D4i luminaire.

According to the specification, control devices are limited respectively to 2W and 1W average power consumption.

Certification program

The Zhaga-D4i certification covers all the critical features including mechanical fit, digital communication, data reporting and power requirements within a single luminaire, ensuring plug-and-play interoperability of luminaires (drivers) and peripherals such as connectivity nodes.

Cost-effective solution

A Zhaga-D4i certified luminaire includes drivers offering features that had previously been in the control node, like energy metering, which has in turn simplified the control device therefore reducing the price of the control system.

Schröder EXEDRA is the most advanced lighting management system on the market for controlling, monitoring and analysing streetlights in a user-friendly way.



Standardisation for interoperable ecosystems

Schröder plays a key role in driving standardisation with alliances and partners such as uCIFI, TALQ or Zhaga. Our joint commitment is to provide solutions designed for vertical and horizontal IoT integration. From the body (hardware) to the language (data model) and the intelligence (algorithms), the complete Schröder EXEDRA system relies on shared and open technologies. Schröder EXEDRA also relies on Microsoft Azure for cloud services, provided with the highest levels of trust, transparency, standards conformance and regulatory compliance.

Breaking the silos

With EXEDRA, Schröder has taken a technology-agnostic approach: we rely on open standards and protocols to design an architecture able to interact seamlessly with third-party software and hardware solutions. Schröder EXEDRA is designed to unlock complete interoperability, as it offers the ability to:

- control devices (luminaires) from other brands
- manage controllers and to integrate sensors from other brands
- connect with third-party devices and platforms

A plug-and-play solution

As a gateway-less system using the cellular network, an intelligent automated commissioning process recognises, verifies and retrieves luminaire data into the user interface. The self-healing mesh between luminaire controllers enables real-time adaptive lighting to be configured directly via the user interface. OWLET IV luminaire controllers, optimised for Schröder EXEDRA, operate Schröder's luminaires and luminaires from third parties. They use both cellular and mesh radio networks, optimising geographical coverage and redundancy for continuous operation.

Tailored experience

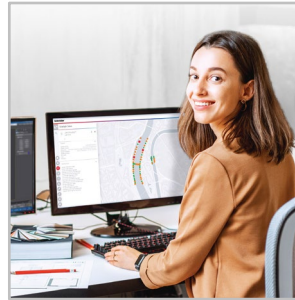

Schröder EXEDRA includes all advanced features needed for smart device management, real-time and scheduled control, dynamic and automated lighting scenarios, maintenance and field operation planning, energy consumption management and third-party connected hardware integration. It is fully configurable and includes tools for user management and multi-tenant policy that enables contractors, utilities or big cities to segregate projects.

A powerful tool for efficiency, rationalisation and decision making

Data is gold. Schröder EXEDRA brings it with all the clarity managers need to drive decisions. The platform collects massive amounts of data from end devices and, aggregates, analyses and intuitively displays them to help end-users take the right actions.

Protected on every side



Schröder EXEDRA provides state-of-the-art data security with encryption, hashing, tokenisation, and key management practices that protect data across the whole system and its associated services. The whole platform is ISO 27001 certified. It demonstrates that Schröder EXEDRA meets the requirements for establishing, implementing, maintaining and continually improving security management.

Mobile App: any time, any place, connect to your street lighting

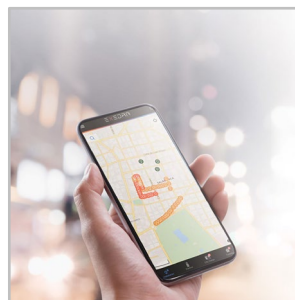

The Schröder EXEDRA mobile application offers the essential functionalities of the desktop platform, to accompany all types of operator on site in their daily effort to maximise the potential of connected lighting. It enables real-time control and settings, and contributes to effective maintenance.

With the PureNight concept, Schröder offers the ultimate solution for restoring the night sky without switching off cities, while maintaining safety and well-being for people and preserving wildlife. The PureNight concept guarantees that your Schröder lighting solution satisfies environmental laws and requirements. Well-designed LED lighting has the potential to improve the environment in all respects.

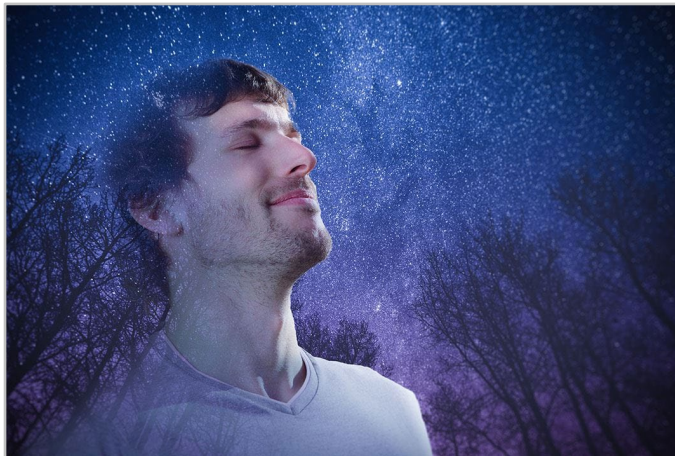

Direct the light only where it is wanted and needed

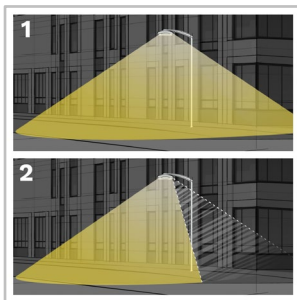

1. Without backlight
2. With backlight

Schröder is renowned for its expertise in photometry. Our optics direct light only where it is wanted and needed. However, light trespass behind the luminaire might be a key concern when it comes to protecting a sensitive wildlife habitat or avoiding intrusive lighting towards buildings. Our fully integrated backlight solutions easily address this potential risk.

Offer maximum visual comfort to people



Because of the lower installation height compared to road lighting, visual comfort is an essential aspect of urban lighting. Schröder designs lenses and accessories to minimise any type of glare (distracting, discomforting, disabling glare and blinding glare). Our design offices harness a range of possibilities to find the best solutions for each project and ensure that we provide a gentle light that delivers the best night-time experience.

Protect wildlife

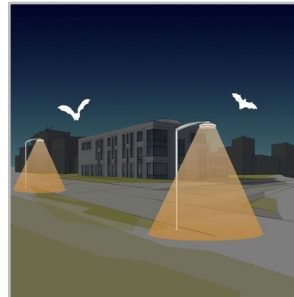

If not well designed, artificial lighting can badly affect wildlife. Blue light and excessive intensity can have a damaging effect on all types of life. Blue light radiation has the ability to suppress the production of melatonin, the hormone that contributes to the regulation of the circadian rhythm. It can also alter the behavioural patterns of animals including bats and moths, as it can change their movements towards or away from light sources. Schröder favours warm white LEDs with minimal blue light, combined with advanced control systems including sensors. This enables permanent adaptation of the lighting to the real needs of the moment, minimising disturbance to the fauna and flora.

Get the starry sky back

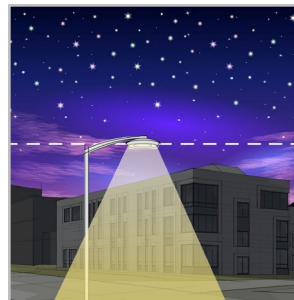

The Upward Light Ratio (ULR) and Upward Light Output Ratio (ULOR), the latter taking the flux from the luminaire into account, provide information on the percentage of light emitted towards the sky. This Schröder range of luminaires minimises or eliminates (depending on the options) upward-directed light flux. It complies with strict international and local requirements.

GENERAL INFORMATION

Circle Light label	Score ≥90 - The product fully meets circular economy requirements
CE mark	Yes
ENEC certified	Yes
ENEC+ certified	Yes
Zhaga-D4i certified	Yes
Testing standard	EN 60598-1 EN 60598-2-1 EN 62262

HOUSING AND FINISH

Housing	Aluminium
Optic	PMMA
Protector	Tempered glass
Housing finish	Polyester powder coating
Standard colour(s)	AKZO grey 900 sanded
Tightness level	IP 66
Impact resistance	IK 08, IK 09
Vibration test	Compliant with ANSI C 136-31 standard, 3G load and modified IEC 68-2-6 (0.5G)
Access for maintenance	Tool-less access to gear compartment

OPERATING CONDITIONS

Operating temperature range (Ta)	-40°C up to +55°C / -40°F up to 131°F with wind effect
----------------------------------	--

· Depending on the luminaire configuration. For more details, please contact us.

ELECTRICAL INFORMATION

Electrical class	Class I EU, Class II EU
Nominal voltage	220-240V – 50-60Hz
Surge protection options (kV)	10
Electromagnetic compatibility (EMC)	EN 55015 / EN 61000-3-2 / EN 61000-3-3 / EN 61547
Control protocol(s)	1-10V, DALI
Control options	AmpDim, Bi-power, Custom dimming profile, Remote management
Socket	Zhaga (optional) NEMA 7-pin (optional)
Associated control system(s)	Schröder EXEDRA

OPTICAL INFORMATION

LED colour temperature	2200K (Warm White WW 722) 2700K (Warm White WW 727) 3000K (Warm White WW 730) 3000K (Warm White WW 830) 4000K (Neutral White NW 740)
Colour rendering index (CRI)	>70 (Warm White WW 722) >70 (Warm White WW 727) >70 (Warm White WW 730) >80 (Warm White WW 830) >70 (Neutral White NW 740)
ULOR	0%
ULR	0%

· ULOR may be different according to the configuration. Please consult us.

· ULR may be different according to the configuration. Please consult us.

LIFETIME OF THE LEDS @ TQ 25°C

All configurations	100,000h - L95
--------------------	----------------

· Lifetime may be different according to the size/configurations. Please consult us.

DIMENSIONS AND MOUNTING

AxBxC (mm inch)	VITALUM EVO 1 : 442x100x209 17.4x3.9x8.2 VITALUM EVO 2 : 535x100x212 21.1x3.9x8.3
Weight (kg lbs)	VITALUM EVO 1 : 3.0-3.8 6.6-8.4 VITALUM EVO 2 : 4.0-4.9 8.8-10.8
Aerodynamic resistance (CxS)	VITALUM EVO 1 : 0.04 VITALUM EVO 2 : 0.06
Mounting possibilities	Side-entry slip-over – Ø48mm Side-entry slip-over – Ø60mm Post-top slip-over – Ø48mm Post-top slip-over – Ø60mm

- For more information about mounting possibilities, please consult the installation sheet.
- Dimensions given with Ø60mm spigot (side-entry mounting)

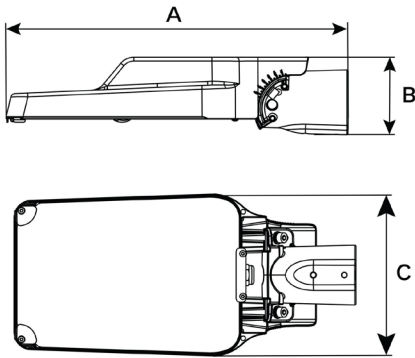

VITALUM EVO | Side-entry slip-over mounting on Ø48-60mm spigots

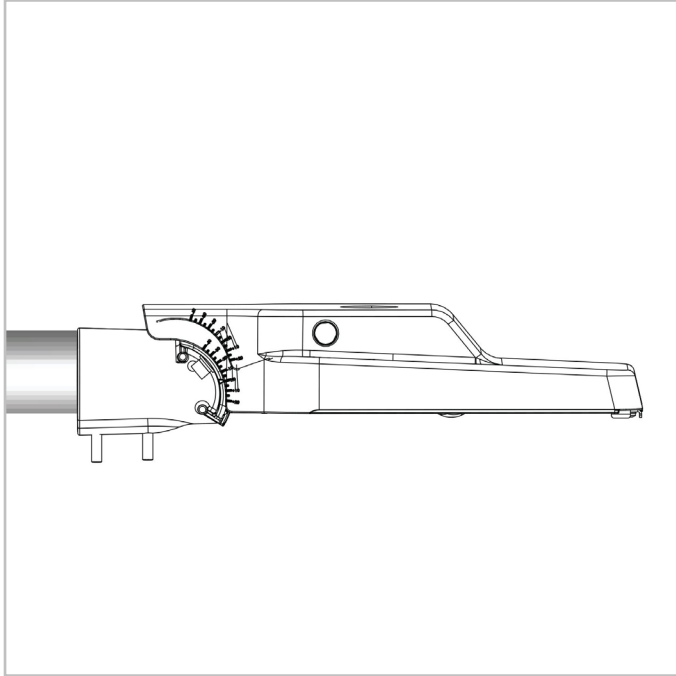

VITALUM EVO | Post-top slip-over mounting on Ø48-60mm spigots

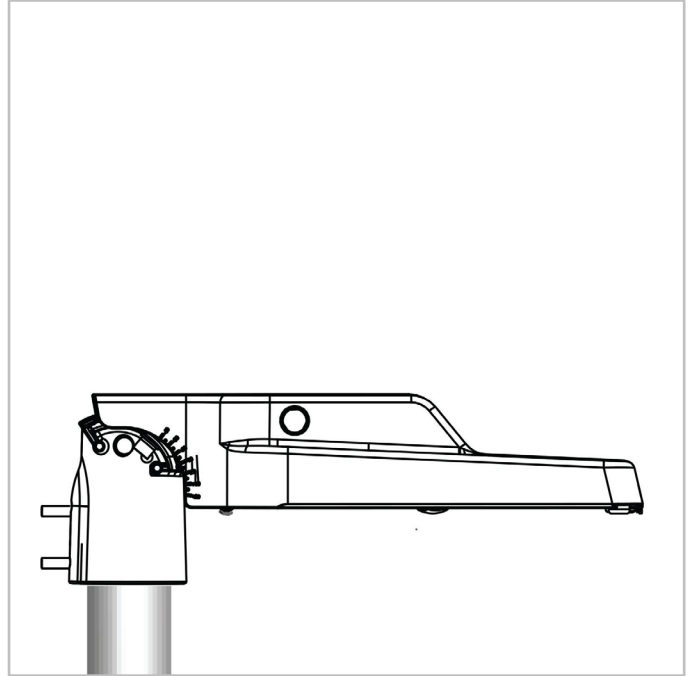

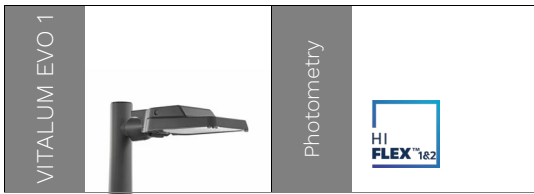

Number of LEDs	Luminaire output flux (lm)								Power consumption (W)		Luminaire efficacy (lm/W)
	Warm White WW 722		Warm White WW 727		Warm White WW 730		Neutral White NW 740				
	Min	Max	Min	Max	Min	Max	Min	Max	Min	Max	Up to
24	1000	5700	1100	6500	1100	6700	1200	7300	10	53	154
36	1500	8600	1700	9700	1800	10100	1900	10900	15	80	161

Tolerance on LED flux is $\pm 7\%$ and on total luminaire power $\pm 5\%$

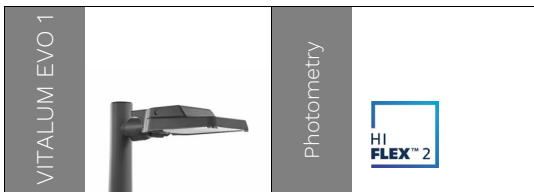

Number of LEDs	Luminaire output flux (lm)								Power consumption (W)		Luminaire efficacy (lm/W)
	Warm White WW 722		Warm White WW 727		Warm White WW 730		Neutral White NW 740				
	Min	Max	Min	Max	Min	Max	Min	Max	Min	Max	Up to
24	1000	5700	1100	6500	1100	6700	1200	7300	10	53	154
36	1500	8600	1700	9700	1800	10100	1900	10900	15	80	161

Tolerance on LED flux is $\pm 7\%$ and on total luminaire power $\pm 5\%$

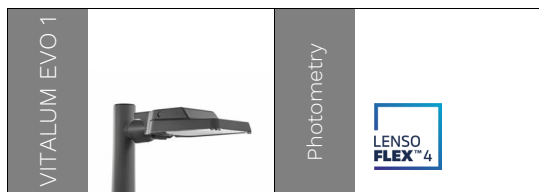

Number of LEDs	Luminaire output flux (lm)										Power consumption (W)		Luminaire efficacy (lm/W)
	Warm White WW 722		Warm White WW 727		Warm White WW 730		Warm White WW 830		Neutral White NW 740				
	Min	Max	Min	Max	Min	Max	Min	Max	Min	Max	Min	Max	Up to
10	400	3000	400	3300	400	3500	400	3300	500	3800	7	30	150
20	800	5800	900	6400	900	6800	900	6400	1000	7400	13	57	159
25	2600	7000	2900	7700	3100	8200	2900	7700	3400	8900	23	68	158

Tolerance on LED flux is $\pm 7\%$ and on total luminaire power $\pm 5\%$



Number of LEDs	Luminaire output flux (lm)								Power consumption (W)		Luminaire efficacy (lm/W)
	Warm White WW 722		Warm White WW 727		Warm White WW 730		Neutral White NW 740				
	Min	Max	Min	Max	Min	Max	Min	Max	Min	Max	Up to
48	2200	10500	2500	11800	2600	12300	2800	13300	19	92	161
72	3100	13900	3500	15700	3600	16300	3900	17500	28	111	174

Tolerance on LED flux is $\pm 7\%$ and on total luminaire power $\pm 5\%$

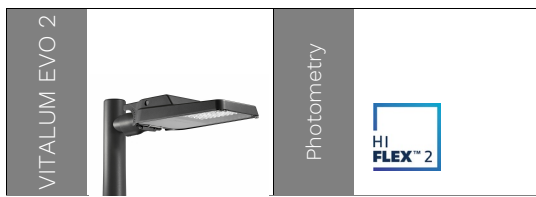

Number of LEDs	Luminaire output flux (lm)								Power consumption (W)		Luminaire efficacy (lm/W)
	Warm White WW 722		Warm White WW 727		Warm White WW 730		Neutral White NW 740				
	Min	Max	Min	Max	Min	Max	Min	Max	Min	Max	Up to
48	2200	10500	2500	11800	2600	12300	2800	13300	19	92	161
72	3100	13900	3500	15700	3600	16300	3900	17500	28	111	174

Tolerance on LED flux is ± 7% and on total luminaire power ± 5 %



Number of LEDs	Luminaire output flux (lm)										Power consumption (W)		Luminaire efficacy (lm/W)
	Warm White WW 722		Warm White WW 727		Warm White WW 730		Warm White WW 830		Neutral White NW 740				
	Min	Max	Min	Max	Min	Max	Min	Max	Min	Max	Min	Max	Up to
30	1200	7900	1300	8700	1400	9300	1300	8700	1600	10100	18	72	166
40	1600	10400	1800	11400	1900	12200	1800	11400	2100	13200	25	97	167
50	6100	12000	6700	13100	7200	14000	6700	13100	7800	15200	52	115	161

Tolerance on LED flux is ± 7% and on total luminaire power ± 5 %

